

# VIKING PUMP

A Unit of IDEX Corporation

Viking® Non-Metallic Mag Drive Pumps

## Sealless, Non-Metallic Pumps for Crucial Liquid Containment Applications

**CMD**  
COMPOSITE MAG DRIVE

- Universal flanges and Motor Adapters
- Standard housing mates to both DIN and ANSI flange systems
- Standard adapters mate to multiple NEMA and IEC motors



Capacity to 125 LPM (33 GPM)  
Pressure to 10 Bar (150 PSI)  
Viscosity 0.8 to 5,000 cSt (28 to 25,000 SSU)  
Temperature -40°C to +65°C (-40°F to +150°F)

**IDEX**  
CORPORATION

# Viking® Reliability in a Sealless, Non-metallic Gear Pump

CMD Mag Drive Series' outer magnets are turned by a motor, and their magnetic force passes through the hermetically sealed canister causing the rotation of the Mag Drive's inner magnets. The inner magnets turn the drive gear shaft, which turns the driven gear, carrying the liquid from the suction to discharge port. The CMD Series pumps combine a proven design with state-of-the-art engineered composites for a structurally rugged, reliable, simple-to-service pump with a lower cost of ownership.

## The Viking Advantages

### Advanced Durability

Viking's CMD series external gear pump is made of engineered fluoropolymers with superior corrosion resistance and strength over a broad range of chemicals and temperatures. Its sealless design eliminates potential leak points, as well as the eddy current energy loss and heat rise common in metallic pumps. Fully encapsulated, self-aligning magnets use patent pending spline design allowing them to "float" on the drive shaft without inducing axial loads, extending service life. With short-term run-dry capabilities supplied by a patent pending bearing design, the CMD series has built-in protection during system upset conditions such as closed suction valve or empty supply tank.

### Ease of Installation

A unique, universal flange design provides easy installation to both ANSI and DIN flanged systems alike. Its robust construction and rigid pump base with slotted holes makes retrofitting of existing installations simple. The close-coupled mounting eliminates the traditional alignment issues with pump and motor for quicker, easier installation. The CMD Series' modular design of magnet hub provides one drive magnet per pump size, with interchangeable adapter-hubs to fit both standard NEMA and IEC motors.

### Application Flexibility

Viking's CMD series' non-metallic construction delivers a broad range of chemical compatibility. Its sealless design provides trouble-free performance where liquid containment is crucial to environmental requirements. This pump series is ideally suited for low-flow operation where centrifugal pumps perform inefficiently and can experience cavitation, increased radial loads and unstable flow. Designed with simple serviceability in mind, you can replace all of the typical wear components easily by removing only the front cover, maximizing uptime.

### Lower Cost of Ownership

Non-metallic construction eliminates the need for expensive alloys. Sealless design eliminates service requirements of mechanical seals and expensive seal flush systems. Run-dry capabilities provide protection against system upsets without catastrophic failure. Advanced design utilizes fewer parts (16 fabricated parts) minimizing maintenance time and inventory requirements. Patent pending casing liner transfers wear from casing to replaceable liner, which is part of the recommended spare parts kit, to provide cost-effective, 100% renewal of CMD pump efficiency and performance for a lower total cost of ownership.

## Performance Envelope

60 Hz – 1750 RPM:

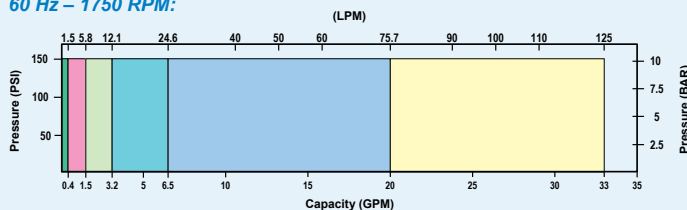

50 Hz – 1450 RPM:

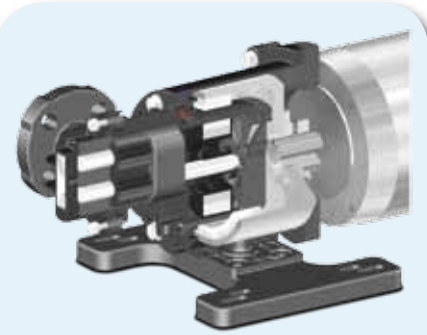
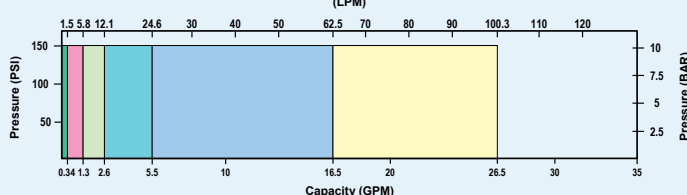

## CMD Series' Benefits

### Vs. Other Mag Drive Gear Pumps:

- CMD offers one of the broadest ranges of chemical resistance in the market, enabling one pump to be used on many different liquids.

### Vs. Non-metallic Mag Drive Centrifugal Pumps:

- CMD offers high efficiencies, usually reducing energy usage, resulting in lower life cycle cost than centrifugals.
- CMD offers flow proportional to speed, allowing use in chemical metering applications.
- CMD handles viscosities from less than 1 to 5,000 cSt, enabling use of one pump on many different liquids.

### Vs. Diaphragm Metering Pumps:

- CMD handles entrained gases better, resulting in lower chance of vapor lock on liquids that off-gas, like sodium hypochlorite.
- CMD offers continuous flow instead of pulsating flow, to eliminate "slug" feeding of chemicals and ensure better mixing.
- Vertical porting option allows replacement of diaphragm metering pumps with minimal repiping.

### Vs. Air Operated Double Diaphragm (AODD) Pumps:

- CMD electric motor drive ensures lower energy usage than compressed air, usually resulting in lower life cycle cost than AODD pumps.
- Eliminates pulsation.

## Corrosive Chemicals



These pumps handle a broad pH range, allowing the same pump to be used for a variety of liquids. They are designed for metering liquids in process control systems as well as for simple tank-to-tank transfer. The fluoropolymer and ceramic wetted materials in these pumps are compatible with many corrosives, yet are more affordable than pumps made of Alloy 20, Alloy C, titanium and other exotic materials required to handle some highly corrosive materials.

### Typical Applications:

- Acids: Hydrochloric, Nitric, Phosphoric, Sulfuric
- Bases: Sodium Hydroxide
- Coagulants: Ferric Chloride
- Disinfectants: Sodium Hypochlorite

## Volatile Organic Chemicals & Flammable Liquids

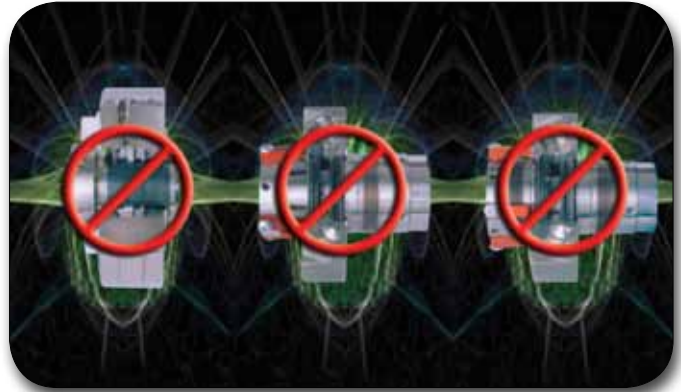

These pumps use a magnetic drive system to eliminate the most common source of pump leakage and vapor emissions, the shaft seal. This helps protect employees and the environment, and it prevents infiltration of air into the pump to protect liquids that react with air or water vapor.

### Typical Applications:

- Solvents: Acetone, Toluene
- Refrigerants: Freons, Ammonia
- Refined Fuels: Ethanol, Biodiesel
- Adhesives: Cyanoacrylate, Epoxies
- Odorants: Mercaptans, Fragrances, Aldehydes
- Organics: Formaldehyde, Vinyl Chloride Monomer

## Model Number Key

<b>CMD</b>	-	<b>E02</b>	<b>E</b>	<b>L</b>	<b>V</b>	<b>F</b>	-	<b>X</b>
Series:		Model:	Materials/Ports:		O-Rings:			Options:
Composite Mag Drive		<b>E02</b>	E = ETFE, FNPT		V = Viton®			A = Bearing Flush Ports
		<b>E05</b>	(E02, E05, E12)		E = EPDM			B = Combination of Options A and N
		<b>E12*</b>	B = ETFE, ISO 7-1					N = Without Drive Magnet
		<b>E25*</b>	(E02, E05, E12)					X = Complete Pump (No Options)
		<b>E75*</b>	F = ETFE, Flange					
		<b>E125*</b>	(E25, E75, E125)					
				<b>Bearings:</b>				
				L = Carbon Graphite				
				B = Graphite-Impregnated Silicon-Carbide				
						<b>Mounting Arrangement:</b>		
						F = NEMA 56C (E02, E05, E12, E25)		
						O = NEMA 143TC-182C (E05, E12, E25, E75, E125)		
						R = NEMA 182TC-184TC (E75, E125)		
						H = IEC B34 63 (E02, E05, E12)		
						K = IEC B34 80 (E02, E05, E12)		
						P = IEC B14 100/112 (E25, E75, E125)		
						Y = No Motor Mount Kit (E02, E05, E12, E25, E75, E125)		

\* Export license required under U.S. Export Administration ECCN 28350 and 28999.

Viton® is a registered trademark of DuPont Performance Elastomers.



# Viking® CMD Series Gear Pump Benefits

ADVANCED DURABILITY

## ■ Innovative Magnet System

Patent pending spline design allows the magnet to self-align on shaft with no added fasteners.

**Eliminates axial loading on shaft, extending pump life.**

## ■ Heavy-Duty Bearings

Self-lubricating materials and patent pending geometry allow dry-run capabilities and generates cooling flow through canister. **Provides built-in protection against system upset, extending pump life, allowing vertical mounting.**

## ■ Non-Metallic Magnet Canister

Minimizes heat rise and magnet inefficiencies due to eddy current losses found in metallic canisters. **Minimizes heat rise to protect sensitive fluids.**

## ■ Unique, Universal Flange

Universal flange design uses replaceable PTFE raised face flange inserts for easy installation to both ANSI and DIN flanged systems. **Eliminates flange adapters, simplifying installation into virtually any system.**

## ■ Rigid Pump Base (E25 & E75 only)

Robust, corrosion resistant base offers optimum pump support in harsh environments. **Slotted holes in base permit easy retrofitting of existing installations.**

## ■ Close-Coupled Mounting

Eliminates coupling, guard, and the cost and issues associated with pump and motor alignment. **Provides quicker, easier installation.**

## ■ Rotatable Casing

3 smaller sizes have rotatable, motor mount casing with NEMA or IEC adapters. **Permits horizontal or vertical porting for easier installation.**

EASY INSTALLATION

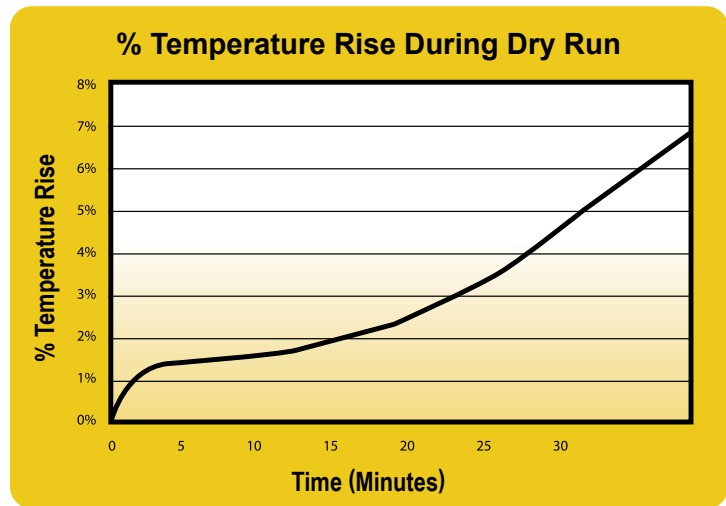

## ■ Short-term Run-Dry Capabilities

High efficiency, self-priming pump with short-term, run-dry capabilities.

**Provides protection against system upsets without catastrophic failure.**

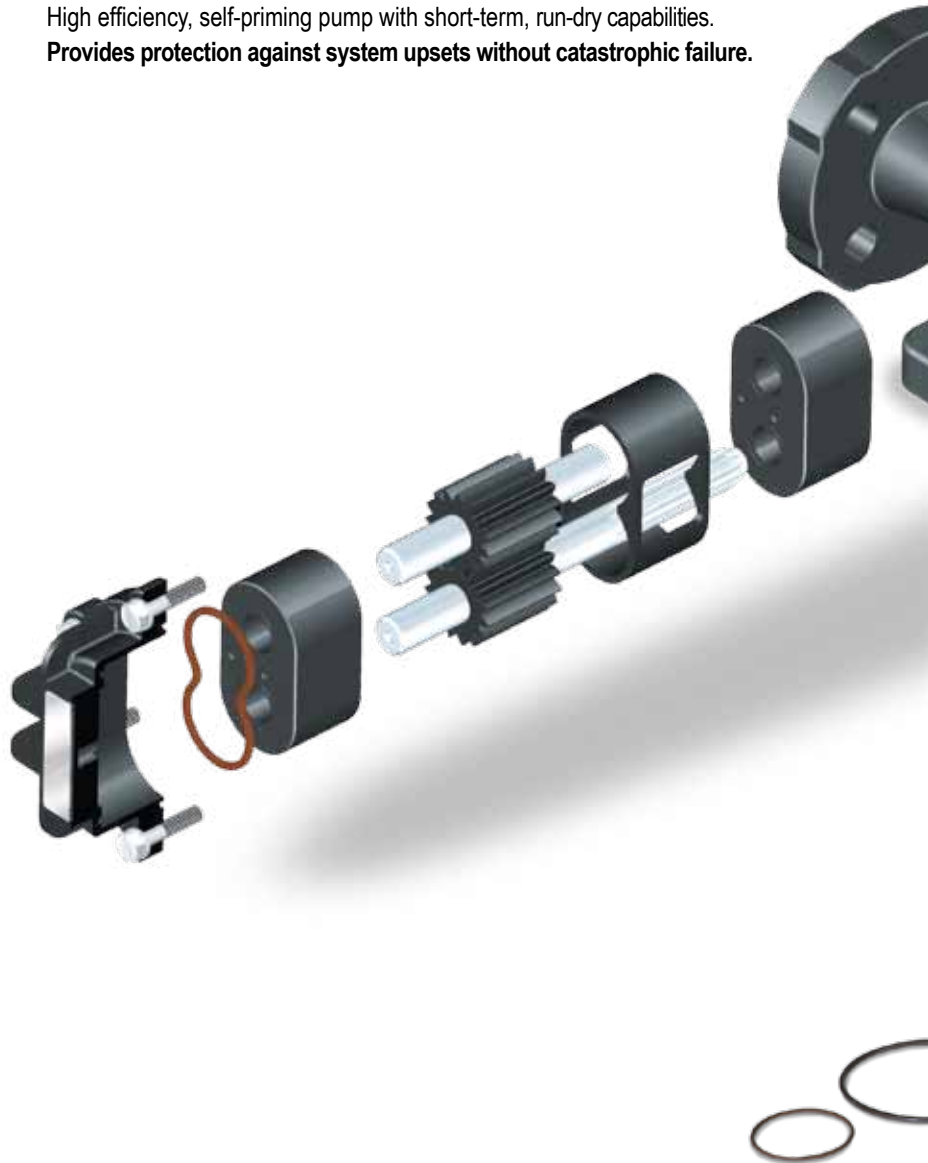

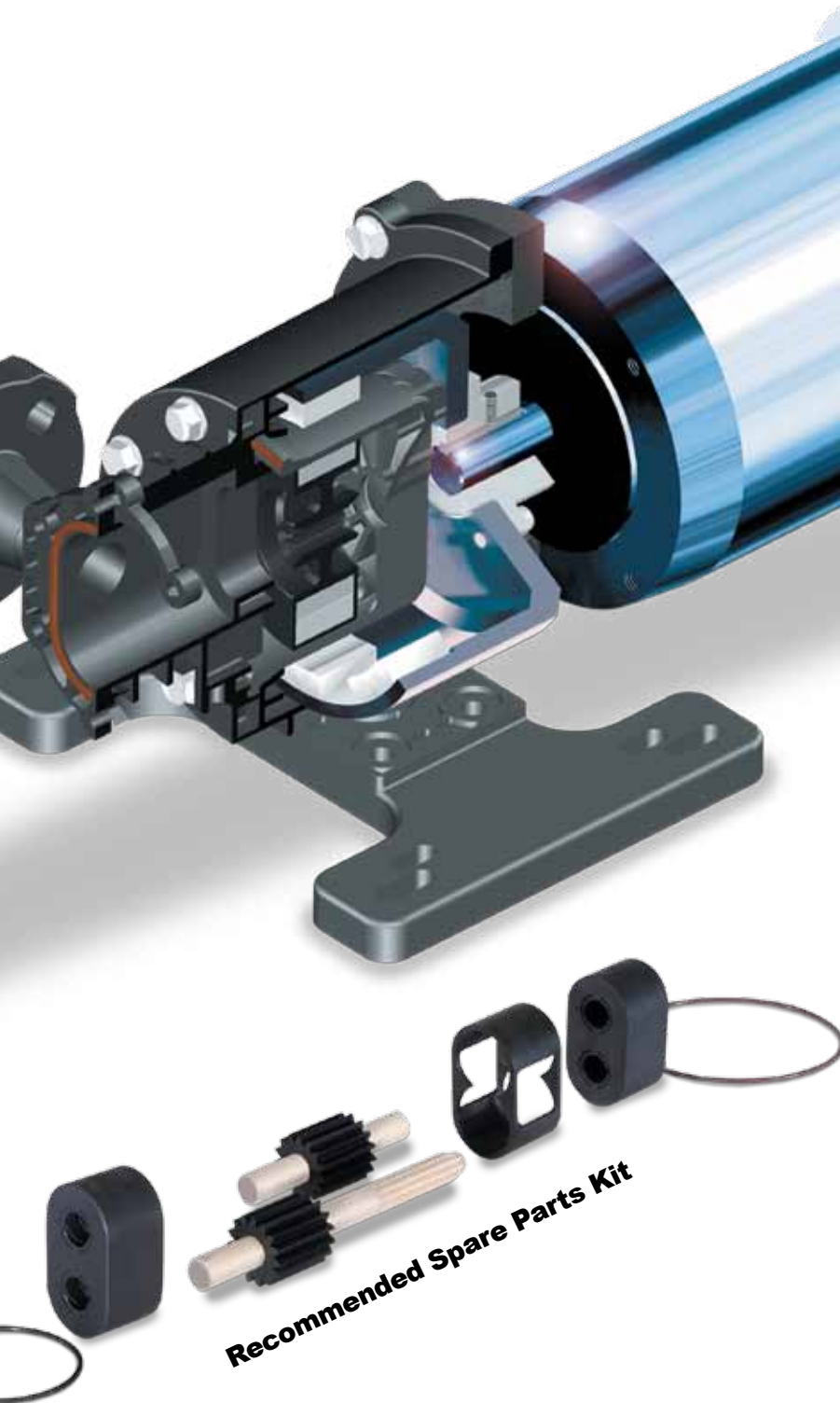

APPLICATION FLEXIBILITY

LOWER COST OF OWNERSHIP

■ **Bi-directional Pump Design**

Bi-directional pumping design eliminates cost of second pump, piping, and valving needed for loading/unloading or line stripping. **Provides application flexibility and reduces system costs.**

■ **Modular Magnet Hub and Universal Motor Adapter**

One drive magnet per pump size, with interchangeable adapter-hubs. **Provides easy mating to fit either standard NEMA or IEC motors.**

■ **Broad Chemical Compatibility**

CMD Series' wetted components are made of Engineered Fluoropolymers, Ceramic and Carbon Graphite-Impregnated Carbide with excellent corrosion resistance and strength over a broad range of chemicals and temperatures. **Enhances application flexibility**

■ **Easy To Assemble**

Better design with self-aligning parts and piloted fits ensure proper assembly every time. **Significantly reduces maintenance costs and parts inventory needs for a lower cost of ownership.**

■ **10 Minute Maintenance**

CMD series' normal wear components can be replaced without detachment of pump from system and no special tools required. **Reduces down time and maintenance costs, for lower cost of ownership.**

■ **Simple Design**

Advanced non-metallic design utilizes fewer parts (16 fabricated parts) to simplify servicing. **Minimizing maintenance requirements and inventory requirements.**

■ **Renewable Performance**

Regain 100 % performance with the change of a recommended spare parts kit, to keep pump running optimally. **Provides cost-effective renewal of pump performance and efficiency.**

# Materials of Construction & Specifications

## CMD Gear Pump Construction

Construction	Casing / Head	Gears	Canister	Inner Magnet Assembly	Outer Magnet Assembly	Shafts	Bearings	O-Rings
<b>Standard</b>	Carbon Reinforced ETFE	Carbon Reinforced PTFE	Carbon Reinforced ETFE	ETFE Encapsulated Neodymium	Nickel-Plated Steel / Neodymium	Alumina Ceramic	Carbon Graphite	Viton®
<b>Optional</b>	N/A	N/A	N/A	N/A	N/A	N/A	Graphite-Impregnated Silicon-Carbide	EPDM

## CMD Gear Pump Specifications

Pump Model	Ports		22 cSt (100 SSU) Performance				Maximum Differential Pressure		Maximum Hydrostatic Pressure		Maximum Recommended Temperature		Approximate Shipping Weight	
	Type	Size in.	Nominal Capacity at 1450 RPM		Nominal Capacity at 1750 RPM									
			GPM	LPM	GPM	LPM	BAR	PSI	BAR	PSI	Deg. C	Deg. F	kg.	lb.
E02	NPT ISO 7-1	1/4	0.34	1.3	0.4	1.5	10	150	14	200	65	150	2	4
E05	NPT ISO 7-1	3/8	1.3	4.9	1.5	5.8	10	150	14	200	65	150	5	9
E12	NPT ISO 7-1	3/4	2.6	10.0	3.2	12.1	10	150	14	200	65	150	6	10
E25	ANSI Flg. DIN Flg.	1	5.5	21.0	6.5	24.6	10	150	14	200	65	150	12	26
E75	ANSI Flg. DIN Flg.	1-1/2	16.5	62.5	20.0	75.0	10	150	14	200	65	150	20	44
E125	ANSI Flg. DIN Flg.	1-1/2	26.5	100.0	33.0	125.0	10	150	14	200	65	150	20	44

Viton® is a registered trademark of DuPont Performance Elastomers.

# Dimensions



## Dimensions For E02, E05 & E12

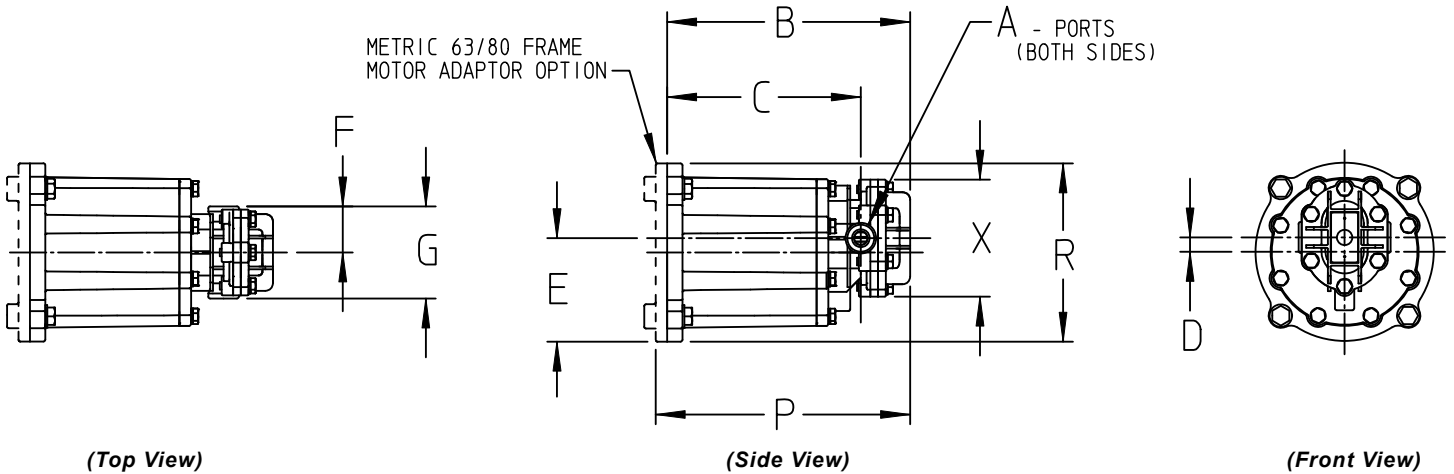

Model		A	B	C	D	E	F	G	P	R	X
E02	mm	1/4 Inch FNPT or ISO 7-1	183.50	154.40	6.40	80.20	34.90	69.90	193.00	147.60	76.20
	in.		7.22	6.08	0.25	3.16	1.38	2.75	7.60	5.81	3.00
E05	mm	3/8 Inch FNPT or ISO 7-1	201.20	160.30	11.90	85.60	38.10	76.20	210.70	147.60	96.80
	in.		7.92	6.31	0.47	3.37	1.50	3.00	8.93	5.81	3.81
E12	mm	3/4 Inch FNPT or ISO 7-1	217.00	168.30	11.90	85.60	47.60	95.30	226.60	147.60	96.80
	in.		8.54	6.63	0.47	3.37	1.88	3.75	8.93	5.81	3.81

NOTE: Pumps must be mounted to a footed motor with a face (NEMA C or Metric B34). Will accept motors with or without a foot/rigid base. Pump foot is removable.

## Dimensions For E25, E75 & E125

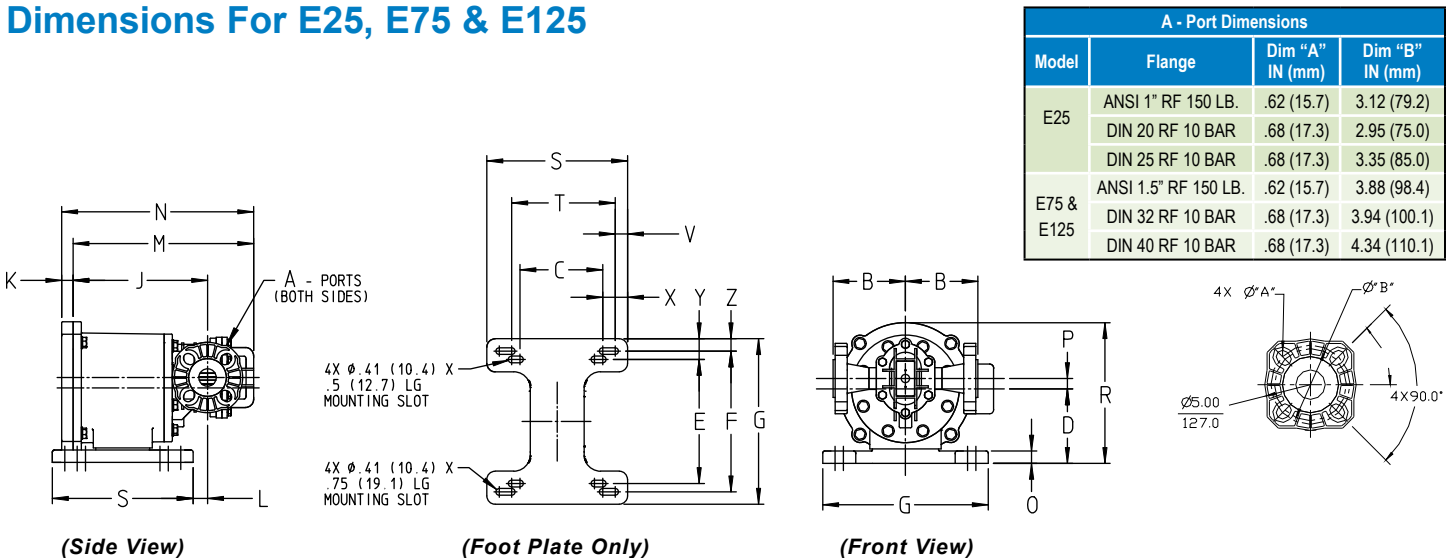

Model		B	C	D	E	F	G	J	K	L	M	N	O	P	R	S	T	V	X	Y	Z
E25	mm	111.10	127.00	114.30	190.50	215.90	254.00	206.40	17.50	22.20	277.10	294.6	19.10	15.90	215.90	215.90	158.8	19.00	38.10	31.7	19.00
	in.	4.38	2 X 5.00	4.50	2 X 7.50	2 X 8.50	10.00	8.12	0.69	0.88	10.91	11.6	0.75	0.62	8.50	8.50	2 x 6.25	2 x .75	2 x 1.50	2 x 1.25	2 x .75
E75 & E125	mm	127.10	127.00	136.50	190.50	215.90	254.00	241.30	25.40	57.10	349.60	375.00	19.10	23.80	257.20	215.90	158.80	19.00	38.10	31.7	19.00
	in.	5.00	2 X 5.00	5.38	2 X 7.50	2 X 8.50	10.00	9.50	1.00	2.25	13.77	14.77	0.75	0.93	10.12	8.50	2 x 6.25	2 x .75	2 x 1.50	2 x 1.25	2 x .75

NOTE: Pumps must be mounted to a motor with a face (NEMA C or Metric B34). Will accept motors with or without a foot/rigid base. Pump foot is removable.



A Unit of IDEX Corporation

# Leader in Positive Displacement Pumping Solutions.

## Innovation and Experience

Viking Pump has been a pump industry leader and innovator since its founding in 1911. We continue to build on our ever growing experience delivering innovative new pumping solutions, including custom designs, to thousands of customers who use Viking pumps in some of the world's toughest applications.

## Broad Performance Range

### Capacity:

0.5 to 360 M<sup>3</sup>/Hr (0.1 to 1,600 GPM)

### Pressure:

0 to 172 Bar (0 to 2,500 PSI)

### Temperature:

-84°C to 370°C (-120°F to 700°F)

### Viscosity:

0.5 to 1,000,000 cSt (28 to 4,500,000 SSU)

## Ultimate in Sealing Solutions

Viking's offering of packing, component mechanical seals, cartridge seals and sealless Mag Drive technology provides the best choices for sealing flexibility needed to provide your application a customized sealing solution every time - saving you money, time and unplanned downtime.

## Material Options Matched to Application

Viking's dedicated iron and alloys foundries provide pump construction materials from cast iron to Alloy C. Application-specific materials of construction extend a pump's life significantly, while reducing maintenance and unplanned downtime, enabling increased production and a better bottom line.

## Liquid Integrity Protection

Viking has developed multiple positive displacement pump principles to protect shear-sensitive liquids, and low-shear options to prevent damage to fibers, polymers and solids. Full-jacketing options provide precise temperature control throughout the pump. The Viking Mag Drive<sup>®</sup> and other seal options prevent fluid contact with air, assuring liquid integrity.

## Local Applications and Engineering Support

Over 245 Authorized Viking Pump Distributors in 68 countries provide local application support and service. They are backed by Viking Application Engineers and Viking Region Managers strategically located around the world.

## Quality Manufacturing

Viking uses ISO9001-2008, Six-Sigma, and Lean/Kaizen in its worldwide manufacturing and assembly processes to remove waste, reduce development costs, and deliver superior products. Dedicated Viking foundries and manufacturing facilities utilize state-of-the-art CNC equipment to assure unmatched quality is built into every pump.

## Custom Designed Solutions

Viking has provided custom designed pumps to end-users and OEMs since its first pump in 1911, when Viking invented the gear-within-a-gear pumping principle to remove water from a rock quarry. Today, enabled by Viking's engineering staff, extensive applications experience and in-house foundries, more than 20% of Viking's sales are new designs or pump designs derived from one of our 40,000 active configurations. Whether you are an end-user or an OEM, Viking can provide custom designed pumping solutions to meet your specific needs.



**For more information, contact your local Authorized Viking Pump Distributor or contact Viking at:**

### VIKING PUMP, INC.

A Unit of IDEX Corporation  
406 State Street  
Cedar Falls, Iowa 50613-0008 U.S.A.  
Telephone: (319) 266-1741  
Fax: (319) 273-8157  
E-mail: [info.viking@idexcorp.com](mailto:info.viking@idexcorp.com)  
Web site: [www.vikingpump.com](http://www.vikingpump.com)

#### CANADA

**Windsor, Ontario**  
Phone: (519) 256-5438  
Fax: (519) 256-5070  
[www.vikingpumpcanada.com](http://www.vikingpumpcanada.com)

#### EUROPE

**Shannon, Ireland**  
Phone: +353 (61) 471933  
Fax: +353 (61) 475046  
[www.vikingpumpeurope.co.uk](http://www.vikingpumpeurope.co.uk)

#### LATIN AMERICA

**Mexico D.F., C.P.**  
Phone: +52 (55) 5255-1357  
Fax: +52 (55) 5255-1356

**Brazil - Sao Paulo**  
Phone: +55 (19) 3871-3500  
Fax: +55 (19) 3871-6400

#### ASIA-PACIFIC GROUP

**Singapore**  
Phone: +65-6763-6633  
Fax: +65-6764-4020  
[www.idexfmt-asia.com](http://www.idexfmt-asia.com)

**China - Shanghai**  
Phone: +86-21-5241-5599  
Fax: +86-21-5241-8339  
[www.idexfmt-asia.com](http://www.idexfmt-asia.com)

**China - Beijing**  
Phone: +86-10-6566-9090  
Fax: +86-10-6567-5152  
[www.idexfmt-asia.com](http://www.idexfmt-asia.com)

**China - Guangzhou**  
Phone: +86-20-3886-6156  
Fax: +86-20-3886-2776  
[www.idexfmt-asia.com](http://www.idexfmt-asia.com)

**India - Mumbai**  
Phone: +91-22-66976634  
Fax: +91-9820334270  
[www.idexfmt-asia.com](http://www.idexfmt-asia.com)

#### ASIA-PACIFIC GROUP

**China - Chengdu**  
Phone: +86-28-86767458  
Fax: +86-28-86767468  
[www.idexfmt-asia.com](http://www.idexfmt-asia.com)

**China - Suzhou**  
Phone: +86-512-62833000  
Fax: +86-512-62833010  
[www.idexfmt-asia.com](http://www.idexfmt-asia.com)

**Korea - Seoul**  
Phone: +82-2-501-3302  
Fax: +82-2-556-0788  
[www.idexfmt-asia.com](http://www.idexfmt-asia.com)

**Australia & New Zealand**  
Phone: +61 2 4577 4534  
Fax: +61 2 4577 5987  
[www.idexfmt-asia.com](http://www.idexfmt-asia.com)

**MIDDLE EAST**  
IDEX Middle East FZE  
**Dubai, UAE**  
Phone: +971-4-299-1095/1097  
Fax: +971-4-299-1069  
[www.idexfmt-asia.com](http://www.idexfmt-asia.com)